

E SC MUSANZE

DATE:09/04/2020

P O BOX 92 RUHENGERI

Class: S₆PCM+S₆PCB

PACKAGE HOLLIDAYS

1. When 1.00 g of hydrogen combines with 8.00 g of oxygen, 9.00 g of water is formed. During this chemical reaction, 2.86×10^5 J of energy is released. How much mass do the constituents of this reaction lose? Is the loss of mass likely to be detectable?
2. A 2 000-kg car moving at 20.0 m/s collides and locks together with a 1 500-kg car at rest at a stop sign. Show that momentum is conserved in a reference frame moving at 10.0 m/s in the direction of the moving car.
3. The speed of light in water is 230 Mm/s. Suppose an electron is moving through water at 250 Mm/s. Does this violate the principle of relativity?
4. Give a physical argument that shows that it is impossible to accelerate an object of mass m to the speed of light, even with a continuous force acting on it.
5. The upper limit of the speed of an electron is the speed of light c . Does that mean that the momentum of the electron has an upper limit?
6. A sodium surface is illuminated with light having a wavelength of 300 nm. The work function for sodium metal is 2.46 eV. **a.** Find the maximum kinetic energy of the ejected photoelectrons. **b.** Find the cutoff wavelength for sodium. **c.** If the threshold wavelength in the photoelectric effect increases when the emitting metal is changed to a different metal, what can you say about the work functions of the two metals?
7. **a.** When a photon scatters off an electron by the Compton effect, which of the following increase: its energy, frequency, wavelength. **b.** X-rays of wavelength of 0.140 nm are scattered from a very thin slice of carbon. What will be the wavelengths of X-rays scattered at **i.** 0° , **ii.** 90° , **iii.** 180° ?
8. **a.** Use the Bohr model to determine the ionization energy of the He^+ ion, which has a single electron. **b.** Also calculate the maximum wavelength a photon can have to cause ionization. **c.** What is the difference between a photon and an electron? Make a list. **d.** In the Rutherford's planetary model of the atom, what keeps the electrons from flying off into space?
9. Red light with wavelength 700 nm is passed through a two very narrow slit apparatus. At the same time, monochromatic visible light with another wavelength passes through the same apparatus. As a result, most of the pattern that appears on the screen is a mixture of two colors; however, the center of the third bright fringe ($k=3$) of the red light appears pure red, with none of the other color. What is the possible wavelengths of the second type of visible light? Do you need to know the slit spacing to answer this question? Why or why not?

10.a) A photon with a wavelength 0.1 nm collides with a free electron that is initially at rest. The wavelength of the photon after the collision is 0.11 nm. i) Why the wavelength of the photon after the collision is greater than the wavelength of the photon before the collision? ii) What is the kinetic energy of the electron after the collision? **b)** If this electron is suddenly stopped in a solid target for example, all of its kinetic energy is used to create a photon. What is the wavelength of this photon?

11.a) An atom initially in an energy level with $E = -6.52 \text{ eV}$ absorbs a photon that has wavelength 860 nm. What is the internal energy of the atom after it absorbs the photon? **b)** An atom initially in an energy level with $E = -2.68 \text{ eV}$ emits a photon that has wavelength 420 nm. What is the internal energy of the atom after it emits the photon?

12. Find the longest and shortest wavelengths in the Lyman and Paschen series for hydrogen. In what region of the electromagnetic spectrum does each series lie?

13.a) Using the Bohr model, calculate the speed of the electron in hydrogen atom in the $n=1, 2$ and 3 levels. **b)** Calculate the orbital period in each of these levels. c) the average lifetime of the first excited level of a hydrogen atom is $1.0 \times 10^{-8} \text{ s}$. In the Bohr model how many orbits does an electron in the $n=2$ level complete before returning to the ground level?

14. Given two $2.00 \mu\text{C}$ charges, as shown in Figure below, and a positive test charge $q = 1.28 \times 10^{-18} \text{ C}$ at the origin, (a) what is the net force exerted by the two $2.00 \mu\text{C}$ charges on the test charge q ? (b) What is the electric field at the origin due to the two $2.00 \mu\text{C}$ charges? (c) What is the electric potential at the origin due to the two $2.00 \mu\text{C}$ charges?

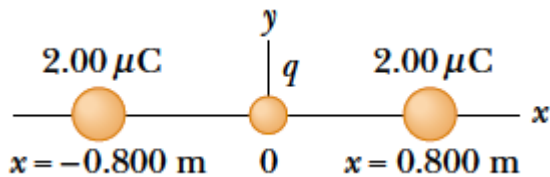

15. Two particles, with charges of 20.0 nC and -20.0 nC , are placed at the points with coordinates $(0, 4.00 \text{ cm})$ and $(0, -4.00 \text{ cm})$, as shown in Figure below. A particle with charge 10.0 nC is located at the origin. **(a)** Find the electric potential energy of the configuration of the three fixed charges. **(b)** A fourth particle, with a mass of $2.00 \times 10^{-13} \text{ kg}$ and a charge of 40.0 nC , is released from rest at the point $(3.00 \text{ cm}, 0)$. Find its speed after it has moved freely to a very large distance away.

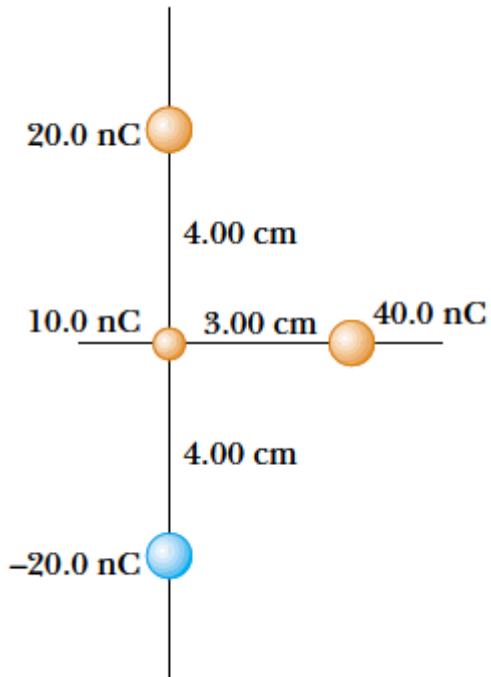

16.a. How does acid rain destroy forests and fish?

b. Basing on relevant examples or case studies, explain how energy resources contribute to the development of some countries. What about Rwanda in that regard?

17. Produce a truth table from the following logic circuit (network)

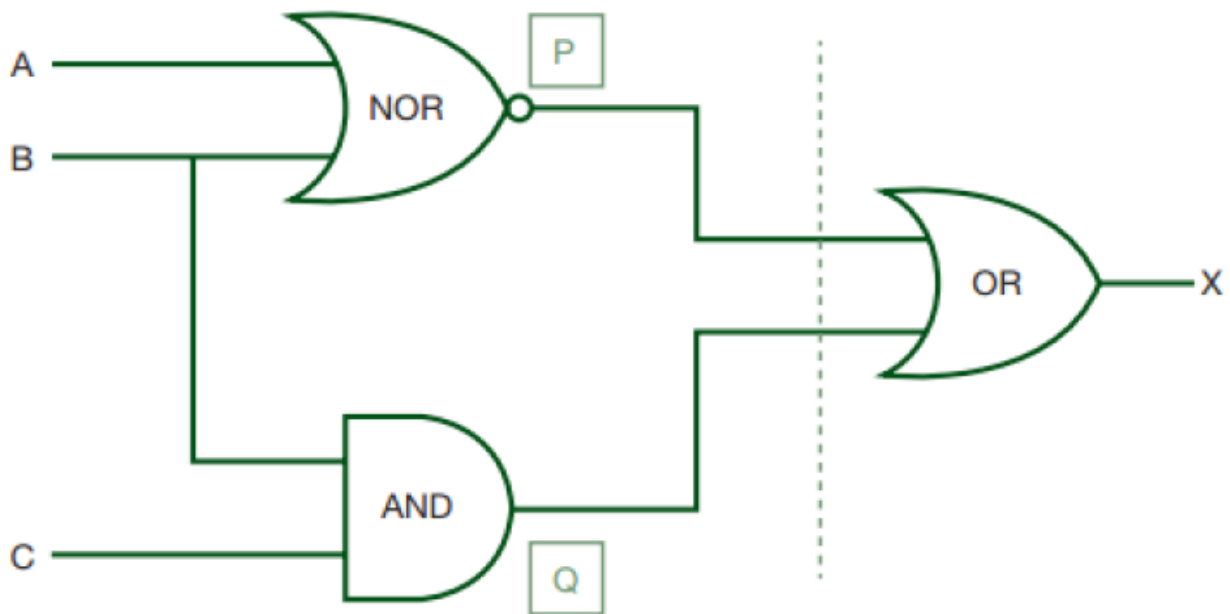

18. Define the following terms used in mobile communication system: a. cell b. cluster c. frequency reuse d. cell splitting

19. Recently, the government of Rwanda decided to replace analog system of communication by digital system of communication. Debate about this government policy

20. Explain briefly positive impact of telecommunication in development of a country like Rwanda.

21.a. Describe a red giant star. List some of its properties.

b. Why do some stars end up as white dwarfs and others as neutron stars or black holes?

END